

50Hz

iT1900 Ice Cube Machine

Models

- IRT1900A IDT-1900A IYT1900A IDT1900N



Designed for operators who know that ice is critical to their business, the Indigo NXT Series ice machine's preventative diagnostics continually monitor itself for reliable ice production. Improvements in cleanability and programmability make your ice machine easy to own and less expensive to operate.

- **New levels of Performance** – Showcasing an average of 13% lower energy consumption and a 10% reduction in potable water usage. This translates into lower cost of ownership over the life of your machine.
- **easyTouch® Display** - New icon based touch screen takes the guess work out of owning and operating an ice machine.
- **Multiple Language Capability** - The easyTouch display is available in multiple languages selected in the initial start-up installation Wizard.
- **Programmable Ice Production** – Now its super easy to program your ice machine to be off at certain times of the day to save money with fluctuating electrical rates. Also programmable by daily ice production volume and night time programming.
- **Easy to Clean Foodzone** – Easy Access front door panel. Removable water-trough, distribution tube, curtain, and sensing probes for fast and efficient cleaning. Select components made with AlphaSan® antimicrobial.
- **Intelligent Diagnostics** – Provides 24 hour preventative maintenance and diagnostic feedback for trouble free operation.
- **Acoustical Ice Sensing Probe** – Unique patented technology allows for reliable operation in challenging water conditions and environments
- **DuraTech® Exterior** – Provides superior corrosion resistant above stainless steel. Innovative clear-coat resists fingerprints and dirt making it easier to keep clean.
- Available **LuminIce® II Virus and Bacteria Inhibitor** – Controls viruses, bacteria, mold and yeast within the food zone to keep the ice machine clean longer. A new sanitation icon lets you know the operational status.
- **Active Sense** - Insures consistent ice harvest in all environmental conditions. This software solution works in conjunction with the acoustical ice sensing probe improving reliability and performance.

Ice Machine Electric

230/ 50/1

Minimum circuit ampacity:

Air-cooled: 16.5 *1ph*
Remote-cooled: 15.8 *1ph*

Maximum fuse size:

Air-cooled: 25 *1ph*
Remote-cooled: 25 *1ph*



Specifications

Operating Limits:

BTU Per Hour:

26,100 (average),
and 30,500 (peak)

Refrigerant:

R-410 CFC-free

- Ambient Temperature Range: 40° to 110° F (4.4° to 43.3° C)
Water Temperature Range: 40° to 90° F (4.4° to 32.2° C)
- Water Pressure Ice Maker
Water In:
Min. 20 psi (137.9 kPa)
Max. 80 psi (551.1 kPa)

Ice Shape



Half Dice
3/8" x 1 1/8" x 7/8"
(.95 x 2.86 x 2.22 cm)
Cube weight 5.7 g



Dice
7/8" x 7/8" x 7/8"
(2.22 x 2.22 x 2.22 cm)
Cube weight 8.5 g



Regular
1 1/8" x 1 1/8" x 7/8"
(2.86 x 2.86 x 2.22 cm)
Cube weight 14.2 g



US LISTED





50Hz

Indigo[®] NXT™ iT1900 Ice Cube Machine

iT1900 on D970 Storage Bin

- Ⓐ Electrical Entrance (2) Options
- Ⓑ 1/2" (1.27 cm) F.P.T. Water Condenser Outlet (water-cooled units)
- Ⓒ 3/8" (0.95 cm) F.P.T. Water Condenser Inlet (water-cooled units)
- Ⓓ 3/8" (0.95 cm) F.P.T. Ice Making Water Inlet
- Ⓔ 1/2" (1.27 cm) F.P.T. Ice Making Water Drain
- Ⓕ 1/2" (1.27 cm) Auxillary Base Drain Socket
- Ⓖ 3/4" (1.91 cm) Bin Drain

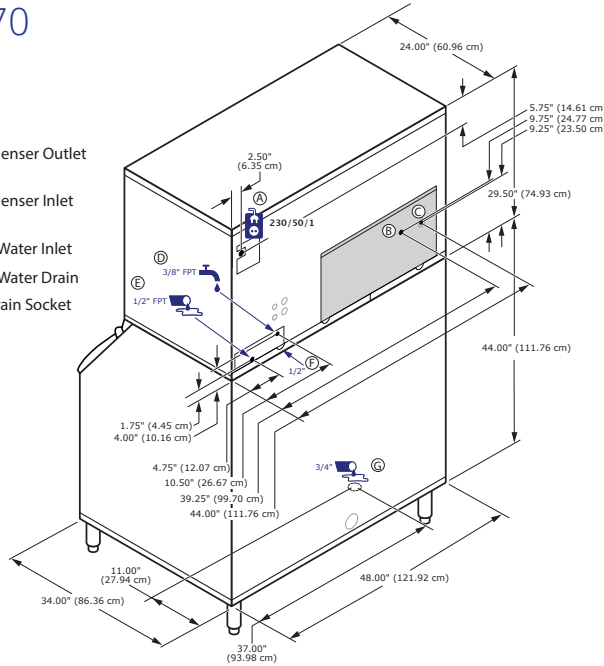

Installation Note
Air Cooled clearance:
 Top: 24" (61.0 cm)
 Sides: 24" (61.0 cm)
 Back: 5" (30.5 cm)
Water Cooled clearance:
 Top/Sides: 8" (20.3 cm)
 Back: 5" (12.7 cm)

Space-Saving Design



	iT1900 D970
Height	79.50" 201.90 cm
Width	48.00" 121.92 cm
Depth	34.00" 86.30 cm
Bin Storage	882 lbs 400 kgs

Height includes adjustable bin legs 6.00" to 8.00", (15.24 to 20.32 cm) set at 6.00" (15.24 cm).

Application capacity measured 90% for the total volume in Cu.ft x 33 lbs/ft³

Specifications

	Model	Ice Shape	Ice Production 24 Hours		Power Usage kWh 45.4 kg / 100 lbs @ 32° Air / 21° C Water 90° Air/70°F Water	Potable Water Usage/100 lbs. 45.4 kgs. of Ice
			21° Air / 10° C Water 70° Air/ 50° F Water	32° Air / 21° C Water 90° Air/ 70° F Water		
AIR-COOLED	IRT1900A	regular	1,700 lbs.	1,275 lbs.	1 Ph	20 Gal.
			771 kgs	578 kgs		
	IDT1900A	dice	1,805 lbs.	1,384 lbs.	4.47	20 Gal.
			819 kgs	628 kgs		
IYT1900A	half-dice	1,805 lbs.	1,430 lbs.	4.32	20 Gal.	
		819 kgs	649 kgs			
REMOTE-COOLED	IDT1900N	dice	1,755 lbs.	1,523 lbs.	3.91	20 Gal.
			796 kgs	691 kgs		

Order separately: Ice storage bin for all units, line-set and remote condenser unit JCT1500 for remote cooled units.
 This product is hermetically sealed and contains fluorinated greenhouse gas R410A

Accessories

LuminIce[®] II Virus and Bacteria Inhibitor
 controls viruses and bacteria in the ice machine.



External Scoop holder
 protect the ice scoop with the NSF approved versatile scoop holder.



Arctic Pure[®] Water Filters
 reduces sediment and chlorine odors for better tasting ice.



Welbilt reserves the right to make changes to the design or specifications without prior notice.

Welbilt Deutschland GmbH
 Auf der Weih 11
 D - 35745 Herborn, Germany
 Tel.: +49 27 72 58 050
 welbilt.com.de

Welbilt Iberia, S.A.U
 Textil, 6 - Pol.Ind. La Ferreria - 08110
 Montcada i Reixac
 Barcelona, Spain
 Tel.: +34 902 20 10 69
 welbilt.com.es

Welbilt UK
 Ashbourne House The Guildway,
 Old Portsmouth Rd Guildford GU3
 1LR United Kingdom
 Tel.: +44 1483 464900
 www.welbilt.uk

