

50Hz

iT0500 Ice Cube Machine

iT0500 Ice Cube Machine

Models

- IRT0500A IDT0500A IYT0500A



Indigo NXT Series iT0500 Ice Machine on D570 Bin
*Ice machine and bin sold separately

Designed for operators who know that ice is critical to their business, the Indigo NXT Series ice machine's preventative diagnostics continually monitor itself for reliable ice production. Improvements in cleanability and programmability make your ice machine easy to own and less expensive to operate.

- **New levels of Performance** - Showcasing an average of 12% lower energy consumption and a 23% reduction in condenser water usage. This translates into lower cost of ownership over the life of your machine.
- **easyTouch® Display** - New icon based touch screen takes the guess work out of owning and operating an ice machine.
- **Multiple Language Capability** - The easyTouch display is available in multiple languages selected in the initial start-up installation Wizard.
- **Programmable Ice Production** - Now its super easy to program your ice machine to be off at certain times of the day to save money with fluctuating electrical rates. Also programmable by daily ice production volume and night time programming.
- **Easy to Clean Foodzone** - Hinge front door swing out for easy access. Removable water-trough, distribution tube, curtain, water probe and water pump for fast and efficient cleaning. Selected components are made with AlphaSan® antimicrobial.
- **Intelligent Diagnostics** - Provides 24 hour preventative maintenance and diagnostic feedback for trouble free operation.
- **Acoustical Ice Sensing Probe** - Unique patented technology allows for reliable operation in challenging water conditions and environments
- **DuraTech® Exterior** - Provides superior corrosion resistant above stainless steel. Innovative clear-coat resists fingerprints and dirt making it easier to keep clean.
- Available **LuminIce® II Virus and Bacteria Inhibitor** - Controls viruses, bacteria, mold and yeast within the food zone to keep the machine clean longer. A new sanitation icon lets you know the operational status.
- **Active Sense** - insures consistent ice harvest in all environmental conditions. This software solution works in conjunction with the acoustical ice sensing probe improving reliability and performance.



Ice Machine Electric

230/50/1

Minimum Circuit Ampacity:

Air-cooled: 5.6

Maximum Fuse Size:

Air Cooled: 15 amps

Specifications

BTU Per Hour:
3,800 (average),
and 6,000 (peak)

Refrigerant:

R410A CFS - Free
Lowers global warming
by 48%

Operating Limits:

- Ambient Temperature Range:
40° to 110° F (4.4° to 43.3° C)
Water Temperature Range:
40° to 90° F (4.4° to 32.2° C)
- Water Pressure Ice Maker
Water In:
Min. 20 psi (137.9 kPa)
Max. 80 psi (551.1 kPa)

Ice Shape



Half Dice
3/8" x 1 1/8" x 7/8"
(.95 x 2.86 x 2.22 cm)
Cube weight 5.7 g



Dice
7/8" x 7/8" x 7/8"
(2.22 x 2.22 x 2.22 cm)
Cube weight 8.5 g



Regular
1 1/8" x 1 1/8" x 7/8"
(2.86 x 2.86 x 2.22 cm)
Cube weight 14.2 g





iT0500 on D-570 Storage Bin

- Ⓐ Electrical Entrance (2) Options
- Ⓑ 3/8" (0.95 cm) F.P.T. Water Condenser Inlet (water-cooled units)
- Ⓒ 1/2" (1.27 cm) F.P.T. Water Condenser Outlet (water-cooled units)
- Ⓓ 1/2" (1.27 cm) Auxillary Base Drain Socket
- Ⓔ 3/8" (0.95 cm) F.P.T. Ice Making Water Inlet
- Ⓕ 1/2" (1.27 cm) F.P.T. Ice Making Water Drain
- Ⓖ 3/4" (1.91 cm) Bin Drain

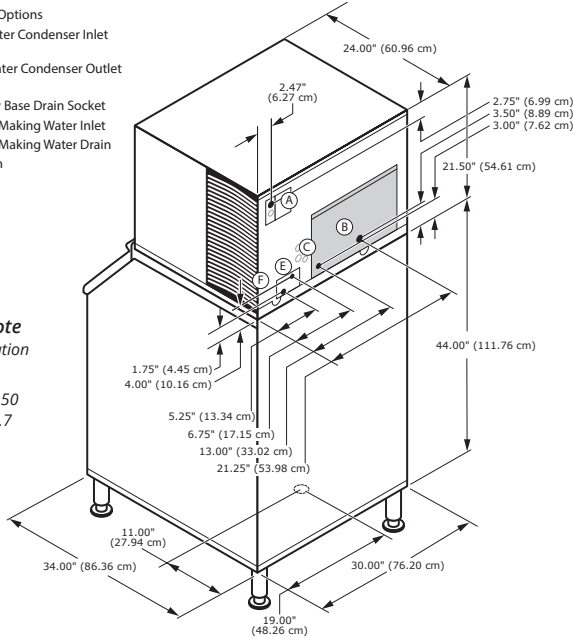

Installation Note
 Minimum installation clearance:
 Top/side: 12" (30.50 cm)
 Back is 5" (12.7 cm)

Space-Saving Design



	iT0500 D-400	iT0500 D-570
Height	59.50" 151.13 cm	71.50" 181.61 cm
Width	30.00" 76.2 cm	30.00" 76.2 cm
Depth	34.00" 86.30 cm	34.00" 86.30 cm
Bin Storage	365 lbs. 165.7 kgs.	532 lbs. 241.1 kgs.

Height includes adjustable bin legs 6.00" to 8.00", (15.24 to 20.32 cm) set at 6.00" (15.24 cm).
 Bin capacity is based on 90% of the volume x 33 lbs/ft³ average density of ice.

Specifications

	Model	Ice Shape	Ice Production 24 Hours		Power Usage kWh 45.4 kg / 100 lbs @ 32°Air / 21°C Water 90°Air / 70°F Water	Potable Water Usage/100 lbs. 45.4 kgs. of Ice
			21°Air / 10°C Water 70°Air / 50°F Water	32°Air / 21°C Water 90°Air / 70°F Water		
AIR COOLED	IRT0500A	Regular 	480 lbs.	370 lbs.	1 Ph	19 Gal.
			218 kgs	168 kgs		71.9 L
	IDT0500A	dice 	500 lbs.	385 lbs.	5.25	19 Gal.
			227 kgs	175 kgs		71.9 L
	IYT0500A	half-dice 	515 lbs.	420 lbs.	4.87	19 Gal.
			234 kgs	191 kgs		71.9 L

*This product is hermetically sealed and contains fluorinated greenhouse gas R404A
 Order ice machine and bin separately*

Accessories

LuminIce® II Virus and Bacteria Inhibitor
 controls viruses and bacteria inside the ice machine.



External Scoop holder
 protect the ice scoop with the NSF approved versatile scoop holder.



Arctic Pure® Water Filters
 reduces sediment and chlorine odors for better tasting ice.



Welbilt reserves the right to make changes to the design or specifications without prior notice.

Welbilt Deutschland GmbH
 Auf der Weih 11
 D - 35745 Herborn, Germany
 Tel.: +49 27 72 58 050
 welbilt.com.de

Welbilt Iberia, S.A.U
 Textil, 6 - Pol.Ind. La Ferreria - 08110
 Montcada i Reixac
 Barcelona, Spain
 Tel.: +34 902 20 10 69
 welbilt.com.es

Welbilt UK
 Ashbourne House
 The Guildford, Old Portsmouth Rd
 Guildford GU3 1LR
 United Kingdom
 Tel.: +44 1483 464900
 www.welbilt.uk

