

S Model Ice Machines

Installation Operation and Maintenance Manual



Original Document

Read this instruction before operating this equipment

America's #1 Selling Ice Machine
Part Number 000006520 Rev 03 12/19

Table of Contents

Section 1 General Information

Model Numbers	4
Ice Deflector	4
Bin Installation	4
Dispenser Installation	4

Section 2 Installation Instructions

Location of Ice Machine	5
Clearance Requirements	5
Ice Machine Heat of Rejection	6
Removing Drain Plug and Leveling the Ice Storage Bin	6
Air Baffle	6
Electrical Service	7
Voltage	7
Fuse/Circuit Breaker	7
Minimum Circuit Ampacity	7
Electrical Requirements	7
Ground Fault Circuit Interrupter	7
Minimum Power Cord Specifications	7
For United Kingdom Only	7
Maximum Breaker Size & Minimum Circuit Amperage Chart	8
Water Supply and Drain Requirements	9
Water Supply	9
Water Inlet Lines	9
Drain Connections	9
Water-Cooled Condenser Water Pressure	9
Cooling Tower Applications (Water-Cooled Models)	9
Water Supply and Drain Line Sizing/Connections	10
Remote Condenser/Line Set Installation	11
Remote Ice Machines	
Refrigerant Charge	11
General	12
Guidelines for Routing Line Sets	12
Calculating Remote Condenser Installation Distances	13
Lengthening or Reducing Line Set Lengths	14
Connecting A Line Set	14
Remote Receiver Service Valve	14
Remote Ice Machine Usage with Non-Manitowoc Multi-Circuit Condensers	15
Warranty	15
Head Pressure Control Valve	15
Fan Motor	15
Internal Condenser Volume	15
Condenser ΔT	15
Refrigerant Charge	15
Quick Connect Fittings	15
Non-Manitowoc Multi-Circuit Condenser Sizing Chart	16
Installation Check List	17
Additional Checks for Remote Models	17
Before Starting the Ice Machine	17

Table of Contents (continued)

**Section 3
Operation**

Ice Making Sequence Of Operation	18
Safety limits	18
Operational Checks	19
General	19
Ice Thickness Check	19

**Section 4
Maintenance**

Cleaning and Sanitizing	20
General	20
Cleaning/Sanitizing Procedure	20
Heavily Scaled Cleaning Procedure	20
Exterior Cleaning	20
Cleaning / Sanitizing Procedure	21
Cleaning Procedure	21
Sanitizing Procedure	22
Procedure to Clean Heavily Scaled Ice Machines	23
Cleaning Procedure	23
Sanitizing Procedure	24
Parts Removal for Cleaning/Sanitizing	26
Exterior Cleaning	28
Door Removal	28
Cleaning the Condenser	28
General	28
Removal from Service/Winterization	28

**Section 5
Customer Support**

Checklist	29
Safety Limit Feature	30
Commercial Ice Machine Warranty	31
Residential Ice Machine Limited Warranty	32

Section 1

General Information

Model Numbers

This manual covers the following models:

Self-Contained Air-Cooled	Self-Contained Water-Cooled	Remote
SD0302A SY0304A	SD0303W SY0305W	----
SD0322A SY0324A	SD0323W SY0325W	----
SR0420A SD0422A SY0424A	SR0421W SD0423W SY0425W	----
SD0452A SY0454A	SD0453W SY0455W	----
SR0500A SD0502A SY0504A	SR0501W SD0503W SY0505W	SR0590N SD0592N SY0594N
SD0602A SY0604A	SD0603W SY0605W	SD0692N SY0694N
SR0850A SD0852A SY0854A	SR0851W SD0853W SY0855W	SR0890N SD0892N SY0894N
SD1002A SY1004A	SD1003W SY1005W SD1003WM	SD1092N SY1094N
SD1202A SY1204A	SD1203W SY1205W	----
SD1402A SY1404A	SD1403W SY1405W SD1403WM	SD1492N SY1494N
SR1600A SD1602A SY1604A	SR1601W SD1603W SY1605W	SR1690N SD1692N SY1694N
SR1800A SD1802A SY1804A	SR1801W SD1803W SY1805W	SR1890N SD1892N SY1894N
----	SD3303W SD3303WHP SY3305W SY3305WHP SD3303WM	----
----	SYT3000W SDT3000W	----

NOTE: Model numbers ending in HP indicate High Pressure water regulating valve. Standard pressure = 150 psi (10.34 bar) High pressure = 350 psi (24.13 bar)

Warning

Remove all ice machine panels before lifting and installing.

ICE DEFLECTOR

An ice deflector is required when the ice machine is installed on a bin. An ice deflector is not required when the ice machine is installed on a dispenser.

Warning

Manitowoc ice machines require a deflector when installed on an ice storage bin.

Prior to using a non-Manitowoc ice storage system with Manitowoc ice machines, contact the manufacturer to assure their ice deflector is compatible with Manitowoc ice machines.

Warning

Do not operate equipment that has been misused, abused, neglected, damaged, or altered/modified from that of original manufactured specifications.

This appliance is not intended for use by persons (including children) with reduced physical, sensory or mental capabilities, or lack of experience and knowledge, unless they have been given supervision concerning use of the appliance by a person responsible for their safety.

Warning

S3000W/ST3000W ice machines are not approved for use on Manitowoc B970 or D970 bins.

BIN INSTALLATION

- All ice machines installed on a bin require an ice deflector.
- Manitowoc bins have a deflector installed and require no modifications when used with a forward facing evaporator.
- Ice machines with multiple evaporators require a deflector kit.

DISPENSER INSTALLATION

- No adapter is needed for machines that match the size of the dispenser unless required by the dispenser manufacturer.
- No deflector is required unless specified by the dispenser manufacturer.
- A bin thermostat to control ice level is recommended.

Section 2

Installation Instructions

Location of Ice Machine

The location selected for the ice machine must meet the following criteria. If any of these criteria are not met, select another location.

- The location must be free of airborne and other contaminants.
- The air temperature must be at least 40°F (4.4°C), but must not exceed 110°F (43.4°C).
- Remote air cooled - The air temperature must be at least -20°F (-29°C), but must not exceed 120°F (49°C).
- The location must not be near heat-generating equipment or in direct sunlight and must be protected from weather.
- The location must not obstruct air flow through or around the ice machine. Refer to the chart below for clearance requirements.

Clearance Requirements

S300	Self-Contained Air-Cooled	Self-Contained Water-Cooled
Top/Sides	16" (40.6 cm)	8" (20.3 cm)
Back	5" (12.7 cm)	5" (12.7 cm)

S320/S450/S500/S600/S850/S1000	Self-Contained Air-Cooled	Water-Cooled and Remote
Top/Sides	8" (20.3 cm)	8" (20.3 cm)
Back	5" (12.7 cm)	5" (12.7 cm)

S420	Self-Contained Air-Cooled	Water-Cooled and Remote
Top/Sides	12" (30.5 cm)	8" (20.3 cm)
Back	5" (12.7 cm)	5" (12.7 cm)

S500 230/50/1 Tropical Rating	Self-Contained Air-Cooled
Top	24" (61 cm)
Sides/Back	12" (30.5 cm)

S1200	Self-Contained Air-Cooled	Water-Cooled and Remote
Top	8" (20.3 cm)	8" (20.3 cm)
Sides	12" (30.5 cm)	8" (20.3 cm)

S1400/S1600/S1800	Self-Contained Air-Cooled	Water-Cooled and Remote
Top/Sides	24" (61.0 cm)	8" (20.3 cm)
Back	12" (30.5 cm)	5" (12.7 cm)

S3300/ST3000*	Water-Cooled
Top/Sides	8" (20.3 cm)
Back	24" (61.0 cm)

*S3300/ST3000 - 24" on all sides is recommended to allow access without moving the bin/ice machine.

Caution

The ice machine must be protected if it will be subjected to temperatures below 32°F (0°C). Failure caused by exposure to freezing temperatures is not covered by the warranty.

Ice Machine Heat of Rejection

Series Ice Machine	Heat of Rejection	
	Air Conditioning	Peak
S300	5000	6000
S320	3800	6000
S420	5900	6900
S450	5900	6900
S500	6100	6900
S600	9000	13900
S850	13000	16000
S1000	17700	21000
S1200	20700	24500
S1400	23500	27000
S1600	21000	31000
S1800	30000	35000
S3300 ST3000	45000	51000

B.T.U./Hour

Because the heat of rejection varies during the ice making cycle, the figure shown is an average.

Ice machines, like other refrigeration equipment, reject heat through the condenser. It is helpful to know the amount of heat rejected by the ice machine when sizing air conditioning equipment where self-contained air-cooled ice machines are installed.

This information is also necessary when evaluating the benefits of using water-cooled or remote condensers to reduce air conditioning loads. The amount of heat added to an air conditioned environment by an ice machine using a water-cooled or remote condenser is negligible.

Knowing the amount of heat rejected is also important when sizing a cooling tower for a water-cooled condenser. Use the peak figure for sizing the cooling tower.

Removing Drain Plug and Leveling the Ice Storage Bin

1. Remove threaded plug from drain fitting.
2. Screw the leveling legs onto the bottom of the bin.
3. Screw the foot of each leg in as far as possible.

⚠ Caution

The legs must be screwed in tightly to prevent them from bending.

4. Move the bin into its final position.
5. Level the bin to assure that the bin door closes and seals properly. Use a level on top of the bin. Turn the base of each foot as necessary to level the bin.
6. Inspect bin gasket prior to ice machine installation. (Manitowoc bins come with a closed cell foam gasket installed along the top surface of the bin.)
7. Remove all panels from ice machine before lifting and installing on bin. Remove both front panels, top cover, left and right side panels.

Air Baffle

SELF-CONTAINED AIR-COOLED ONLY

The air-cooled baffle prevents condenser air from recirculating. To install:

1. Remove the back panel screws next to the condenser.
2. Align the mounting holes in the air baffle with the screw holes and reinstall the screws.

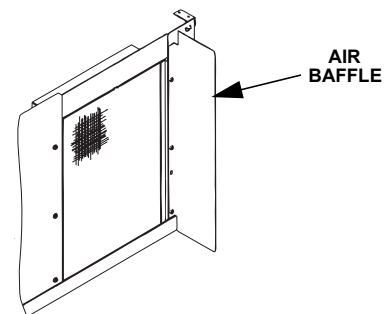

Electrical Service

Warning

All wiring must conform to local, state and national codes.

VOLTAGE

The maximum allowable voltage variation is $\pm 10\%$ of the rated voltage at ice machine start-up (when the electrical load is highest).

Warning

The ice machine must be grounded in accordance with national and local electrical codes.

All electrical work, including wire routing and grounding, must conform to local, state and national electrical codes. The following precautions must be observed:

- The ice machine must be grounded.
- A separate fuse/circuit breaker must be provided for each ice machine.
- A qualified electrician must determine proper wire size dependent upon location, materials used and length of run (minimum circuit ampacity can be used to help select the wire size).
- The maximum allowable voltage variation is $\pm 10\%$ of the rated voltage at ice machine start-up (when the electrical load is highest).
- Check all green ground screws in the control box and verify they are tight before starting the ice machine.

Important

Observe correct polarity of incoming line voltage. Incorrect polarity can lead to erratic ice machine operation.

FUSE/CIRCUIT BREAKER

A separate fuse/circuit breaker must be provided for each ice machine. Circuit breakers must be H.A.C.R. rated (does not apply in Canada).

MINIMUM CIRCUIT AMPACITY

The minimum circuit ampacity is used to help select the wire size of the electrical supply. (Minimum circuit ampacity is not the ice machine's running amp load.)

The wire size (or gauge) is also dependent upon location, materials used, length of run, etc., so it must be determined by a qualified electrician.

ELECTRICAL REQUIREMENTS

Refer to Ice Machine Model/Serial Plate for voltage/ampere specifications.

GROUND FAULT CIRCUIT INTERRUPTER

Ground Fault Circuit Interrupter (GFCI/GFI) protection is a system that shuts down the electric circuit (opens it) when it senses an unexpected loss of power, presumably to ground. Manitowoc Ice does not recommend the use of a GFCI/GFI circuit protection with our equipment. If code requires the use of a GFCI/GFI then you must follow the local code. The circuit must be dedicated, sized properly and there must be a panel GFCI/GFI breaker. We do not recommend GFCI/GFI outlets as they are known for more intermittent nuisance trips than panel breakers.

MINIMUM POWER CORD SPECIFICATIONS

Maximum Breaker Size	Minimum Wire Size	Maximum Length of Power Cord
15 amp	14 gauge	6 feet (1.83 m)
20 amp	12 gauge	6 feet (1.83 m)
30 amp	10 gauge	6 feet (1.83 m)
40 amp	8 gauge	6 feet (1.83 m)

If a power cord is used, the wire size to the receptacle is dependent upon location, materials used, length of run, etc., so it must be determined by a qualified electrician. Local, state or national requirements will supersede our minimum requirements.

FOR UNITED KINGDOM ONLY

As the colors of the wires in the mains lead of the appliance may not correspond with the colored markings identifying the terminals in your plug, proceed as follows:

- The wire which is colored green and yellow must be connected to the terminal in the plug which is marked with the letter E or by the earth ground symbol  or colored green or green and yellow.
- The wire colored blue must be connected to the terminal which is marked with the letter N or colored black.
- The wire colored brown must be connected to the terminal which is marked with the letter L or colored red.

Maximum Breaker Size & Minimum Circuit Amperage Chart.

Due to continuous improvements, this information is for reference only. Please refer to the ice machine serial number tag to verify electrical data. Serial tag information overrides information listed on this page							
Ice Machine	Voltage/ Phase/ Cycle	Air-Cooled		Water Cooled		Remote	
		Maximum Fuse/Circuit Breaker	Minimum Circuit Amps	Maximum Fuse/Circuit Breaker	Minimum Circuit Amps	Maximum Fuse/Circuit Breaker	Minimum Circuit Amps
S300	115/1/60	25	15.6	25	14.8	N/A	N/A
	230/1/50	15	7.4	15	6.9	N/A	N/A
	230/1/60	15	6.7	15	6.3	N/A	N/A
S320	115/1/60	15	11.3	15	10.5	N/A	N/A
	208-230/1/60	15	6.0	15	5.6	N/A	N/A
	230/1/50	15	6.0	15	5.6	N/A	N/A
S420/S450	115/1/60	20	14.2	20	13.5	N/A	N/A
	208-230/1/60	15	6.1	15	5.7	N/A	N/A
	230/1/50	15	7.1	15	6.8	N/A	N/A
S500	115/1/60	20	20.0	20	13.5	25	20.0
	208-230/1/60	15	6.1	15	5.7	15	8.3
	230/1/50	15	7.1	15	6.8	15	6.7
S600	208-230/1/60	15	8.3	15	7.9	15	8.9
	230/1/50	15	6.7	15	6.1	15	7.1
S850	208-230/1/60	20	11.9	20	10.9	20	11.9
	208-230/3/60	15	9.2	15	8.2	15	9.2
	230/1/50	20	10.8	20	9.4	15	10.4
S1000	208-230/1/60	30	17.3	30	16.3	25	15.7
	208-230/3/60	15	10.6	15	9.6	15	10.6
	230/1/50	20	12.7	20	11.3	20	12.3
	460/3/60	N/A	N/A	15	4.5	N/A	N/A
S1200	208-230/1/60	35	25.0	35	25.0	N/A	N/A
	208-230/3/60	20	16.0	20	16.0	N/A	N/A
	230/1/50	30	20.0	30	20.0	N/A	N/A
S1400	208-230/1/60	30	18.3	30	16.9	30	17.9
	208-230/3/60	20	13.2	20	11.8	20	12.8
	230/1/50	30	15.1	30	13.7	30	14.7
	440-480/3/60	N/A	N/A	15	6.4	N/A	N/A
S1600	208-230/1/60	30	19.8	30	18.4	30	19.4
	208-230/3/60	20	13.5	20	12.1	20	13.1
	230/1/50	30	16.7	30	15.3	30	16.3
S1800	208-230/1/60	40	23.8	40	22.4	40	23.4
	208-230/3/60	25	15.4	25	14.0	25	15.0
	230/1/50	40	21.9	40	20.5	40	21.5
S3300	208-230/1/60	N/A	N/A	N/A	N/A	N/A	N/A
	208-230/3/60	N/A	N/A	30	30	N/A	N/A
	230/1/50	N/A	N/A	N/A	N/A	N/A	N/A
	440-480/3/60	N/A	N/A	15	9.9	N/A	N/A
ST3000	208-230/3/60	N/A	N/A	30	30	N/A	N/A

S3300/ST3000 - Verify the direction of rotation correct is correct on the 3ph scroll compressor. The ice machine will have high suction pressure, low discharge pressure and will be noticeably loud. Reverse any two incoming power leads to reverse rotation.

Water Supply and Drain Requirements

WATER SUPPLY

Local water conditions may require treatment of the water to inhibit scale formation, filter sediment, and remove chlorine odor and taste.

WATER INLET LINES

Follow these guidelines to install water inlet lines:

- If you are installing a Manitowoc Arctic Pure water filter system, refer to the Installation Instructions supplied with the filter system for ice making water inlet connections.
- Do not connect the ice machine to a hot water supply. Be sure all hot water restrictors installed for other equipment are working. (Check valves on sink faucets, dishwashers, etc.)
- If water pressure exceeds the maximum recommended pressure of 80 psi (552 kPa), obtain a water pressure regulator from your Manitowoc distributor.
- Install a water shut-off valve for both the ice making and condenser water lines.
- Insulate water inlet lines to prevent condensation.

Caution

Do not apply heat to water valve inlet fitting. This will damage plastic water inlet connection.

DRAIN CONNECTIONS

Follow these guidelines when installing drain lines to prevent drain water from flowing back into the ice machine and storage bin:

- Drain lines must have a 1.5 inch drop per 5 feet of run (2.5 cm per meter), and must not create traps.
- The floor drain must be large enough to accommodate drainage from all drains.
- Run separate bin and ice machine drain lines. Insulate them to prevent condensation.
- Vent the bin and ice machine drain to the atmosphere. Do not vent the condenser drain on water-cooled models.
- S3300/ST3000 require a base drain connection (3/4" FPT).

WATER-COOLED CONDENSER WATER PRESSURE

Water pressure at the condenser cannot exceed 350 psig (10.34 bar).

COOLING TOWER APPLICATIONS (WATER-COOLED MODELS)

A water cooling tower installation does not require modification of the ice machine. The water regulator valve for the condenser continues to control the refrigeration discharge pressure.

It is necessary to know the amount of heat rejection, and the pressure drop through the condenser and water valves (inlet and outlet) when using a cooling tower on an ice machine.

- Water entering the condenser must not exceed 90°F (32.2°C).
- Water flow through the condenser must not exceed 5 gallons (19 liters) per minute.
- Allow for a pressure drop of 7 psi (0.5 bar) between the condenser water inlet and the outlet of the ice machine.
- Water exiting the condenser must not exceed 110°F (43.3°C).

Important

The Commonwealth of Massachusetts requires that all water-cooled models must be connected only to a closed loop, cooling tower system.

Water Supply and Drain Line Sizing/Connections

⚠ Caution
Plumbing must conform to state and local codes.

Location	Water Temperature	Water Pressure	Ice Machine Fitting	Tubing Size Up to Ice Machine Fitting
Ice Making Water Inlet	35°F (1.6°C) Min. 90°F (32.2°C) Max.	20 psi (1.4 bar) Min. 80 psi (5.52 bar) Max.	3/8" (.95 cm) Female Pipe Thread	3/8" (.95 cm) min inside diameter 1/2" (1.27 cm) S3300/ST3000 Only
Ice Making Water Drain	---	---	1/2" (1.27 cm) Female Pipe Thread 3/4" (1.91 cm) FPT S3300/ST3000 3/4" (1.91 cm) FPT Base Drain S3300/ST3000 Only	1/2" (1.27 cm) min inside diameter 3/4" (1.91 cm) S3300/ST3000 Only
Condenser Water Inlet	90°F (32.2°C) Max.	Standard 20 psi (1.4 bar) Min. 150 psi (10.34 bar) Max. High Pressure Option 20 psi (1.4 bar) Min. 350 psi (24.1 bar) Max.	3/8" Female Pipe Thread 3/4" Female Pipe Thread S3300/ST3000 Only	
Condenser Water Drain	---	---	1/2" (1.27 cm) Female Pipe Thread 3/4" (1.91 cm) FPT S3300/ST3000	1/2" (1.27 cm) min inside diameter 3/4" (1.91 cm) S3300/ST3000 Only
Bin Drain	---	---	3/4" (1.91 cm) Female Pipe Thread	3/4" (1.91 cm) minimum inside diameter
Large Capacity Bin Drain	---	---	1" (2.54 cm) Male Pipe Thread	1" (2.54 cm) min. inside diameter

The exact locations of inlets and drains for the model you are working on may vary.

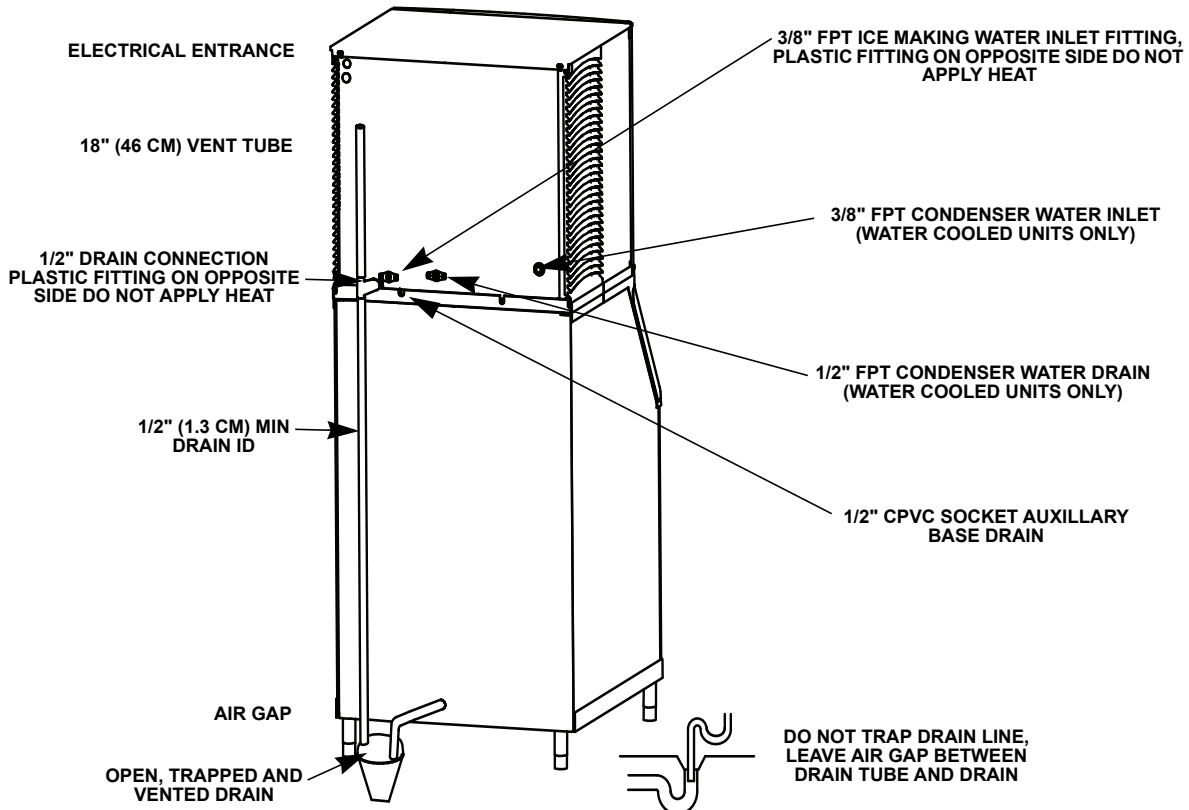

Typical Water Supply Drain Installation

Remote Condenser/Line Set Installation

Ice Machine	Remote Single Circuit Condenser	Line Set*
S500	JC0495	RT-20-R404A RT-35-R404A RT-50-R404A
S600/S800/S1000	JC0895	RT-20-R404A RT-35-R404A RT-50-R404A
S1400/S1600/S1800	JC1395	RL-20-R404A RL-35-R404A RL-50-R404A

*Line Set	Discharge Line	Liquid Line
RT	1/2" (1.27 cm)	5/16" (.79 cm)
RL	1/2" (1.27 cm)	3/8" (.95 cm)

Air Temperature Around the Condenser	
Minimum	Maximum
-20°F (-29°C)	120°F (49°C)

Important

Manitowoc remote systems are only approved and warranted as a complete new package. Warranty on the refrigeration system will be void if a new ice machine head section is connected to pre-existing (used) tubing or remote condensers.

REMOTE ICE MACHINES REFRIGERANT CHARGE

Each remote ice machine ships from the factory with a refrigerant charge appropriate for installation with line sets of up to 50' (15.25 m). The serial tag on the ice machine indicates the refrigerant charge.

Additional refrigerant may be required for installations using line sets between 50' and 100' (15.25-30.5 m) long. If additional refrigerant is required, refer to the chart below for the correct amount to be added.

Important
EPA CERTIFIED TECHNICIANS

If remote line set length is between 50' and 100' (15.25 and 30.5 m), add additional refrigerant to the nameplate charge. Refer to the table below for the model being worked on.

Tubing length: _____

Refrigerant added to nameplate: _____

New total refrigerant charge: _____

 **Warning**
Potential Personal Injury Situation

The ice machine contains refrigerant charge. Installation of the line sets must be performed by a properly trained and EPA certified refrigeration technician aware of the **dangers of dealing with refrigerant** charged equipment.

 **Caution**

Never add more than nameplate charge to the refrigeration system for any application.

Ice Machine	Nameplate Charge (Charge Shipped in Ice Machine)	Refrigerant to be Added for 50'-100' Line Sets	Maximum System Charge (Never Exceed)
S500	6 lb. (96 oz.)	1.5 lb. (24 oz.)	7.5 lb. (120 oz.)
S600	6.5 lb. (104 oz.)	1.5 lb. (24 oz.)	8 lb. (128 oz.)
S850	8.5 lb. (136 oz.)	2 lb. (32 oz.)	10.5 lb. (168 oz.)
S1000	8.5 lb. (136 oz.)	2 lb. (32 oz.)	10.5 lb. (168 oz.)
S1400	11 lb. (176 oz.)	2 lb. (32 oz.)	13 lb. (208 oz.)
S1600	11.5 lb. (184 oz.)	2 lb. (32 oz.)	13.5 lb. (216 oz.)
S1800	12.5 lb. (200 oz.)	1 lb. (16 oz.)	13.5 lb. (216 oz.)

GENERAL

Condensers must be mounted horizontally with the fan motor on top with nothing obstructing it. There must be at least a 16" (41 cm) clearance from the bottom for air intake. The front coupling panel and one other panel (back or side) must also be unobstructed.

Remote condenser installations consist of vertical and horizontal line sets between the ice machine and the condenser. When combined, they must fit within approved specifications. The following guidelines, drawings and calculation methods must be followed to verify a proper remote condenser installation.

⚠ Caution

The 60 month compressor warranty (including the 36 month labor replacement warranty) will not apply if the remote ice machine is not installed according to specifications.

This warranty also will not apply if the refrigeration system is modified with a condenser, heat reclaim device, or other parts or assemblies not manufactured by Manitowoc Ice unless specifically approved in writing by Manitowoc Ice.

GUIDELINES FOR ROUTING LINE SETS

First, cut a 2.5" (6.35 cm) circular hole in the wall or roof for tubing routing. The line set end with the 90° bend will connect to the ice machine. The straight end will connect to the remote condenser.

Follow these guidelines when routing the refrigerant lines. This will help ensure proper performance and service accessibility.

1. Optional - Make the service loop in the line sets (as shown below). This permits easy access to the ice machine for cleaning and service. Do not use hard rigid copper at this location.
2. Required - Do not form traps in the refrigeration lines (except the service loop). Refrigerant oil must be free to drain toward the ice machine or the condenser. Route excess tubing in a supported downward horizontal spiral (as shown below). Do not coil tubing vertically.
3. Required - Keep outdoor refrigerant line runs as short as possible.

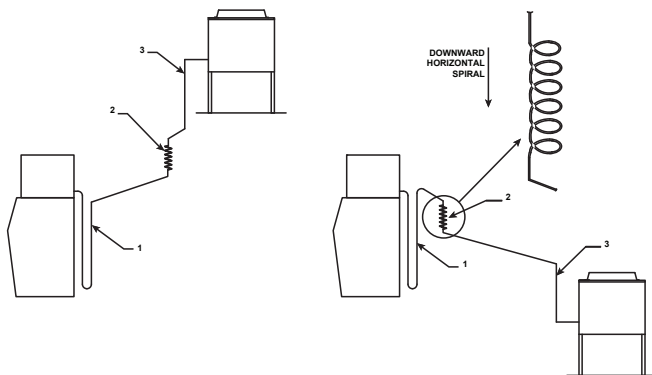

Routing Line Sets

CALCULATING REMOTE CONDENSER INSTALLATION DISTANCES

Line Set Length

The maximum length is 100' (30.5 m).

The ice machine compressor must have the proper oil return. The receiver is designed to hold a charge sufficient to operate the ice machine in ambient temperatures between -20°F (-29°C) and 120°F (49°C), with line set lengths of up to 100' (30.5 m).

Line Set Rise/Drop

The maximum rise is 35' (10.7 m).

The maximum drop is 15' (4.5 m).

⚠ Caution

If a line set has a rise followed by a drop, another rise cannot be made. Likewise, if a line set has a drop followed by a rise, another drop cannot be made.

Make the following calculations to make sure the line set layout is within specifications.

1. Insert the **measured rise** into the formula below. Multiply by 1.7 to get the **calculated rise**. (Example: A condenser located 10 feet above the ice machine has a **calculated rise** of 17 feet.)
2. Insert the **measured drop** into the formula below. Multiply by 6.6 to get the **calculated drop**. (Example. A condenser located 10 feet below the ice machine has a **calculated drop** of 66 feet.)
3. Insert the **measured horizontal distance** into the formula below. No calculation is necessary.
4. Add together the **calculated rise**, **calculated drop**, and **horizontal distance** to get the **total calculated distance**. If this total exceeds 150' (45.7 m), move the condenser to a new location and perform the calculations again.

Calculated Line Set Distance

The maximum calculated distance is 150' (45.7 m).

Line set rises, drops, horizontal runs (or combinations of these) in excess of the stated maximums will exceed compressor start-up and design limits. This will cause poor oil return to the compressor.

Maximum Line Set Distance Formula

Step 1.	Measured Rise (35' [10.7 m] Maximum)	_____ x 1.7	=	_____	Calculated Rise
Step 2.	Measured Drop (15' [4.5 m] Maximum)	_____ x 6.6	=	_____	Calculated Drop
Step 3.	Measured Horizontal Distance (100' [30.5 m] Maximum)			_____	Horizontal Distance
Step 4.	Total Calculated Distance 150' (45.7 m)			_____	Total Calculated Distance

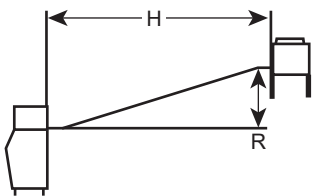

SV1196

Combination of a Rise and a Horizontal Run

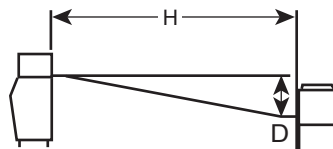

SV1195

Combination of a Drop and a Horizontal Run

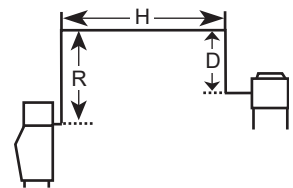

SV1194

Combination of a Rise, a Drop and a Horizontal Run

LENGTHENING OR REDUCING LINE SET LENGTHS

In most cases, by routing the line set properly, shortening will not be necessary. When shortening or lengthening is required, do so before connecting the line set to the ice machine or the remote condenser. This prevents the loss of refrigerant in the ice machine or condenser.

The quick connect fittings on the line sets are equipped with Schraeder valves. Use these valves to recover any vapor charge from the line set. When lengthening or shortening lines follow good refrigeration practices, purge with nitrogen and insulate all tubing. Do not change the tube sizes. Evacuate the lines and place about 5 oz (143g) of vapor refrigerant charge in each line.

CONNECTING A LINE SET

1. Remove the dust caps from the line set, condenser and ice machine.
2. Apply refrigeration oil to the threads on the quick disconnect couplers before connecting them to the condenser.
3. Carefully thread the female fitting to the condenser or ice machine by hand.
4. Tighten the couplings with a wrench until they bottom out.
5. Turn an additional 1/4 turn to ensure proper brass-to-brass seating. Torque to the following specifications:

Liquid Line	Discharge Line
10-12 ft lb. (13.5-16.2 N•m)	35-45 ft lb. (47.5-61.0 N•m)

6. Check all fittings and valve caps for leaks.
7. Make sure Schraeder cores are seated and Schraeder caps are on and tight.

REMOTE RECEIVER SERVICE VALVE

The receiver service valve is closed during shipment. Open the valve prior to starting the ice machine.

1. Remove the top and left side panels.
2. Remove the receiver service valve cap.
3. Backseat (open) the valve.
4. Reinstall the cap and panels.

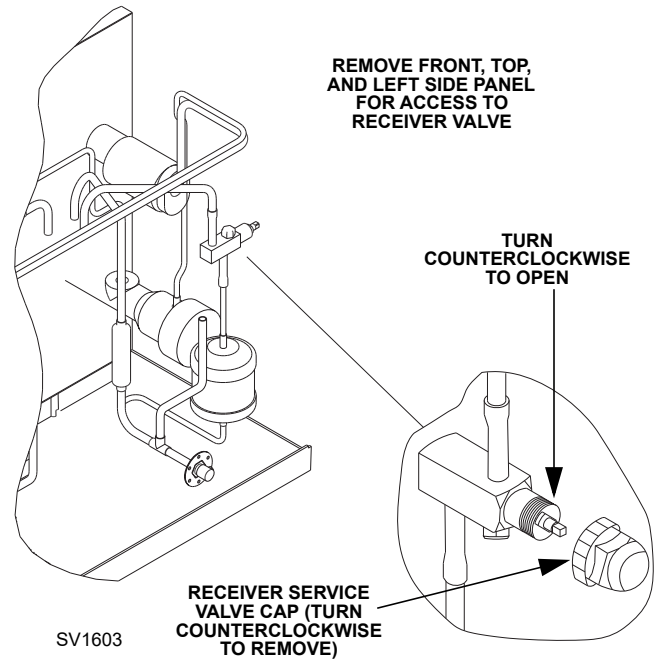

Backseating the Receiver Service Valve

Remote Ice Machine Usage with Non-Manitowoc Multi-Circuit Condensers

WARRANTY

The sixty (60) month compressor warranty, including thirty six (36) month labor replacement warranty, **shall not apply** when the remote ice machine is not installed within the remote specifications. The foregoing warranty shall not apply to any ice machine installed and/or maintained inconsistent with the technical instructions provided by Manitowoc Ice, Inc. Performance may vary from Sales specifications. S-Model ARI certified standard ratings only apply when used with a Manitowoc remote condenser.

If the design of the condenser meets the specifications, Manitowoc's only approval is for full warranty coverage to be extended to the Manitowoc manufactured part of the system. Since Manitowoc does not test the condenser in conjunction with the ice machine, Manitowoc will not endorse, recommend, or approve the condenser, and will not be responsible for its performance or reliability.

Important

Manitowoc warrants only complete new and unused remote packages. Guaranteeing the integrity of a new ice machine under the terms of our warranty prohibits the use of pre-existing (used) tubing or condensers.

HEAD PRESSURE CONTROL VALVE

Any remote condenser connected to a Manitowoc S-Model Ice Machine must have a head pressure control valve (available from Manitowoc Distributors) installed on the condenser package. Manitowoc **will not accept** substitute "off the shelf" head pressure control valves.

Caution

Do not use a fan cycling control to try to maintain discharge pressure. Compressor failure will result.

FAN MOTOR

The condenser fan must be **on** during the complete ice machine freeze cycle (do not cycle on fan cycle control). The ice maker has a condenser fan motor circuit for use with a Manitowoc condenser. It is recommended that this circuit be used to control the condenser fan(s) on the multi-circuit condenser to assure it is on at the proper time. **Do not exceed the rated amps for the fan motor circuit listed on the ice machine's serial tag.**

INTERNAL CONDENSER VOLUME

The multi-circuit condenser internal volume must not be less than or exceed that used by Manitowoc (see chart on next page). **Do not exceed internal volume and try to add charge to compensate, as compressor failure will result.**

CONDENSER ΔT

ΔT is the difference in temperature between the condensing refrigerant and entering air. The ΔT should be 15 to 20°F (-9.4 to -6.6°C) at the beginning of the freeze cycle (peak load conditions) and drop down to 12 to 17°F (-11.1 to -8.3°C) during the last 75% of the freeze cycle (average load conditions).

REFRIGERANT CHARGE

Remote ice machines have the serial plate refrigerant charge (total system charge) located in the ice maker section. (Remote condensers and line sets are supplied with only a vapor charge.)

Caution

Never add more than nameplate charge to ice machine for any application.

QUICK CONNECT FITTINGS

The ice machine and line sets come with quick connect fittings. It is recommended that matching quick connects (available through Manitowoc Distributors) be installed in the multi-circuit condenser, and that a vapor "holding" charge, 5 oz. (150 ml), of proper refrigerant be added to the condenser prior to connection of the ice machine or line set to the condenser.

NON-MANITOWOC MULTI-CIRCUIT CONDENSER SIZING CHART

Ice Machine Model	Refrigerant		Heat of Rejection		Internal Condenser Volume (cu ft)		Design Pressure	Quick Connect Stubs-Male Ends		Head Pressure Control Valve
	Type	Charge	Average Btu/hr	Peak Btu/hr	Min	Max		Discharge	Liquid	
S500	R-404A	6 lbs.	6,100	6,900	0.020	0.035	500 psig (3447 kpa) (34.47 bar) safe working pressure 2,500 psig (17237 kpa) (172.37 bar) burst pressure	coupling P/N 83-6035-3	coupling P/N 83-6034-3	Manitowoc P/N 83-6809-3 no substitutes
S600	R404A	6.5 lbs.	9,000	13,900	0.045	0.060				
S850	R-404A	8.5 lbs.	13,000	16,000	0.045	0.060				
S1000	R-404A	8.5 lbs.	17,700	21,000	0.045	0.060		mounting flange P/N 83-6006-3	mounting flange P/N 83-6005-3	
S1400	R-404A	11 lbs.	20,700	24,500	0.085	0.105				
S1600	R-404A	11.5 lbs	21,000	31,000	0.085	0.105				
S1800	R-404A	12.5 lbs.	30,000	35,000	0.085	0.105				

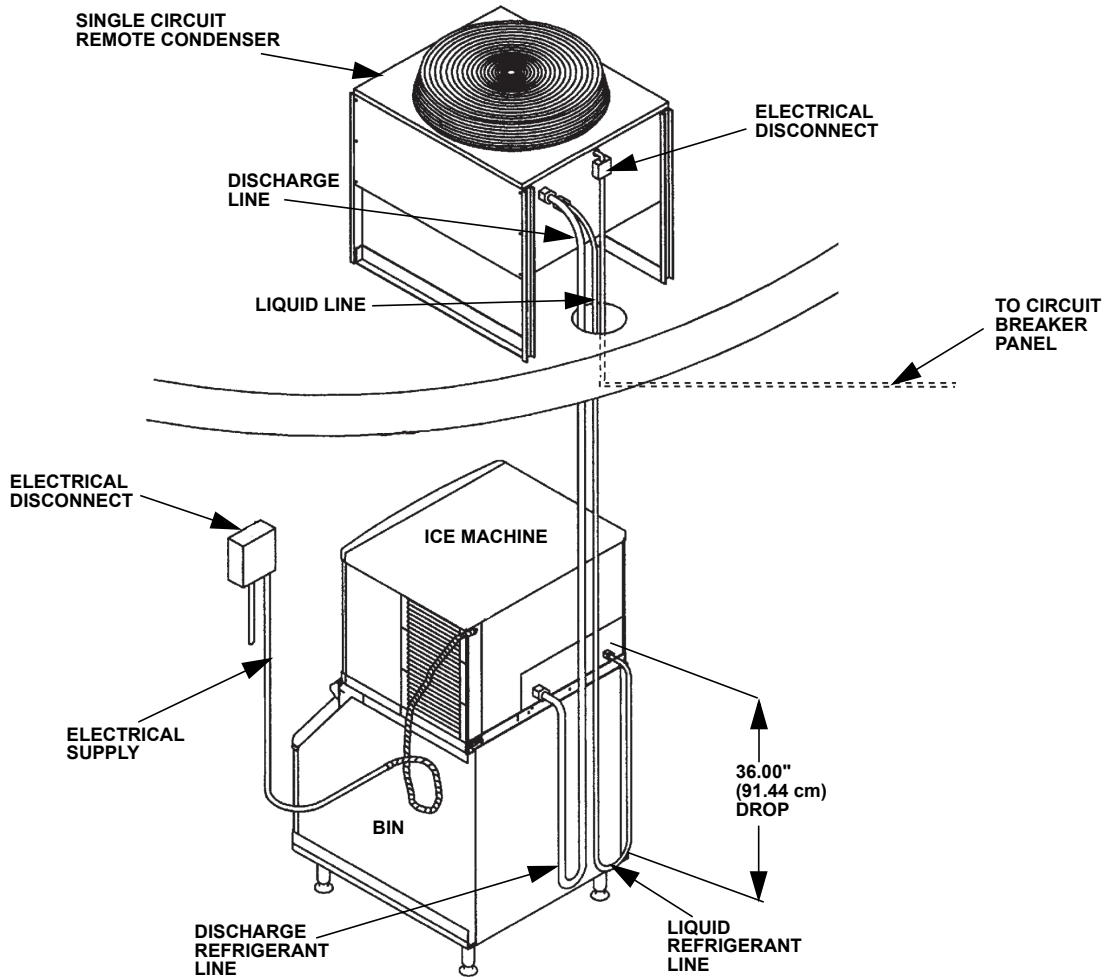

Typical Single Circuit Remote Condenser Installation

Installation Check List

- Is the Ice Machine level?
- Have all of the electrical and water connections been made?
- Has the supply voltage been tested and checked against the rating on the nameplate?
- Is there proper clearance around the ice machine for air circulation?
- Is the ice machine grounded and polarity correct?
- Has the ice machine been installed where ambient temperatures will remain in the range of 35° - 110°F (1.6° - 43.3°C)?
- Has the ice machine been installed where the incoming water temperature will remain in the range of 35° - 90°F (1.6° - 32.2°C)?
- Is there a separate drain for the potable water, bin and water-cooled condenser?
- Are the ice machine and bin drains vented?
- Are all electrical leads free from contact with refrigeration lines and moving equipment?
- Has the owner/operator been instructed regarding maintenance and the use of Manitowoc Cleaner and Sanitizer?
- Has the owner/operator completed the warranty registration card?
- Has the ice machine and bin been sanitized?
- Is the toggle switch set to ice? (The toggle switch is located directly behind the front panel).
- Is the ice thickness control set correctly? (Refer to Operational Checks to check/set the correct ice bridge thickness).

- S3300/ST3000 Only** - Is the compressor direction of rotation correct? The ice machine will have high suction pressure, low discharge pressure and will be noticeably loud. Reverse any two incoming power leads to reverse rotation.

Additional Checks for Remote Models

- Has the receiver service valve been opened?
- Does the remote condenser fan operate properly after start-up?
- Has the remote condenser been located where ambient temperatures will remain in the range of -20° - 120°F (-29 - 49°C).
- Is the line set routed properly?
- Are both refrigeration lines to remote condenser run so they do not lay in water and are properly insulated?

Before Starting the Ice Machine

All Manitowoc ice machines are factory-operated and adjusted before shipment. Normally, new installations do not require any adjustment.

To ensure proper operation, follow the Operational Checks in Section 3 of this manual. Starting the ice machine and completing the Operational Checks are the responsibilities of the owner/operator.

Adjustments and maintenance procedures outlined in this manual are not covered by the warranty.

Warning

Potential Personal Injury Situation

Do not operate equipment that has been misused, abused, neglected, damaged, or altered/modified from that of original manufactured specifications.

Section 3

Operation

Ice Making Sequence Of Operation

NOTE: The toggle switch must be in the ice position and the water curtain/ice dampers must be in place on the evaporator before the ice machine will start.

Water Purge Cycle

The ice machine purges any remaining water from the water trough down the drain.

Freeze Cycle

Water flows across the evaporator and the refrigeration system chills the evaporator. Ice builds on the evaporator until water contacts the ice thickness probe.

Harvest Cycle

Any remaining water is purged down the drain as refrigerant gas warms the evaporator. When the evaporator warms, the sheet of cubes slides off the evaporator and into the storage bin. If all cubes fall clear of the water curtain (or ice damper) the ice machine starts another freeze cycle.

Off Cycle

If the water curtain or ice damper are held open by ice cubes the ice machine shuts off. When the water curtain or ice damper closes the ice machine starts a new cycle at the water purge.

Control Board Timers

The control board has the following non-adjustable timers:

- The ice machine is locked into the freeze cycle for 6 minutes before a harvest cycle can be initiated. Freeze lock is bypassed after moving the toggle switch from OFF to ICE position for the first cycle only.
- The maximum freeze time is 60 minutes at which time the control board automatically initiates a harvest sequence.
- The maximum harvest time is 3.5 minutes for single evaporators and 7 minutes for multiple evaporator model. The control board automatically initiates a freeze sequence when these times are exceeded.

SAFETY LIMITS

Safety limits are stored and indicated by the control board after three cycles. The number of cycles required to stop the ice machine varies for each safety limit.

- Safety Limit 1 *all models* - If the freeze time reaches 60 minutes, the control board automatically initiates a harvest cycle. If 6 consecutive 60-minute freeze cycles occur, the ice machine stops.
- Safety Limit 2 *single evaporator models* - If the harvest time reaches 3.5 minutes, the control board automatically returns the ice machine to the freeze cycle. If 500 consecutive 3.5 minute harvest cycles occur, the ice machine stops.
- Safety Limit 2 *multiple evaporator models* - If the harvest time reaches 7 minutes, the control board automatically returns the ice machine to the freeze cycle. If 500 consecutive 7 minute harvest cycles occur, the ice machine stops.
- Safety Limit 3 *multiple evaporator models* - If the low refrigerant pressure control opens, the ice machine shuts off and starts a 5 minute delay period. If 3 consecutive low pressure events occur, the ice machine stops and flashes the harvest light.

Use the following procedures to determine if the control board contains a safety limit indication.

1. Move the toggle switch to OFF.
2. Move the toggle switch back to ICE. Watch the safety limit lights/harvest light on the control board. If a safety limit has been recorded, the corresponding light will blink once, twice or three times to indicate which safety limit stopped the ice machine.

Operational Checks

GENERAL

Manitowoc ice machines are factory-operated and adjusted before shipment. Normally, new installations do not require any adjustment.

To ensure proper operation, always follow the Operational Checks:

- when starting the ice machine for the first time
- after a prolonged out of service period
- after cleaning and sanitizing

NOTE: Routine adjustments and maintenance procedures are not covered by the warranty.

Important

Scroll refrigeration compressors must be operated for a minimum break in period of 24 hours before full ice production will be reached.

ICE THICKNESS CHECK

After a harvest cycle, inspect the ice cubes in the ice storage bin. The ice thickness probe is factory-set to maintain the ice bridge thickness at 1/8" (3 mm).

NOTE: Make sure the water curtain is in place when performing this check. It prevents water from splashing out of the water trough.

1. Inspect the bridge connecting the cubes. It should be about 1/8" (3 mm) thick.
2. If adjustment is necessary, turn the ice thickness probe adjustment screw clockwise to increase bridge thickness, counterclockwise to decrease bridge thickness. Set at 1/4" (6 mm) gap between ice machine and evaporator as starting point, then adjust to achieve a 1/8" (3 mm) bridge thickness.

NOTE: Turning the adjustment 1/3 of a turn will change the ice thickness about 1/16" (1.5 mm).

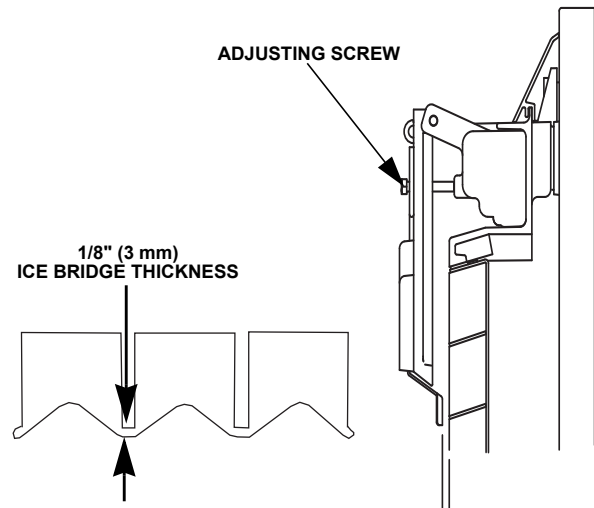

Ice Thickness Check

3. Make sure the ice thickness probe wire and the bracket do not restrict movement of the probe.

Section 4

Maintenance

Descaling and Sanitizing

GENERAL

You are responsible for maintaining the ice machine in accordance with the instructions in this manual. Maintenance procedures are not covered by the warranty.

Descal and sanitize the ice machine every six months for efficient operation. If the ice machine requires more frequent descaling and sanitizing, consult a qualified service company to test the water quality and recommend appropriate water treatment. An extremely dirty ice machine must be taken apart for cleaning and sanitizing.

Manitowoc Ice Machine Cleaner and Sanitizer are the only products approved for use in Manitowoc ice machines.

Caution

Use only Manitowoc approved Ice Machine Cleaner/Descaler and Sanitizer for this application (Manitowoc Cleaner part number 94-0546-3 and Manitowoc Sanitizer part number 94-0565-3). It is a violation of Federal law to use these solutions in a manner inconsistent with their labeling. Read and understand all labels printed on bottles before use.

Caution

Do not mix Cleaner/Descaler and Sanitizer solutions together. It is a violation of Federal law to use these solutions in a manner inconsistent with their labeling.

Warning

Wear rubber gloves and safety goggles (and/or face shield) when handling Ice Machine Cleaner or Sanitizer.

CLEANING/SANITIZING PROCEDURE

This procedure must be performed a minimum of once every six months.

- The ice machine and bin must be disassembled cleaned and sanitized.
- All ice produced during the cleaning and sanitizing procedures must be discarded.
- Removes mineral deposits from areas or surfaces that are in direct contact with water.

REMEDIAL CLEANING PROCEDURE

Perform this procedure if you have some or all of these symptoms.

- Ice machine stops on Safety Shutdown.
- Your water has a high concentration of minerals.
- The ice machine has not been on a regular maintenance schedule.

DETAILED DESCALING/SANITIZING PROCEDURE

This procedure must be performed a minimum of once every six months.

- The ice machine and bin must be disassembled descaled and sanitized.
- All ice produced during the descaling and sanitizing procedures must be discarded.

EXTERIOR CLEANING

Clean the area around the ice machine as often as necessary to maintain cleanliness and efficient operation. Use cleaners designed for use with stainless steel products.

Sponge any dust and dirt off the outside of the ice machine with mild soap and water. Wipe dry with a clean, soft cloth.

Heavy stains should be removed with stainless steel wool. Never use plain steel wool or abrasive pads. They will scratch the panels.

Remedial Cleaning Procedure

⚠ Caution

Use only Manitowoc approved Ice Machine Cleaner/Descaler and Sanitizer for this application (Manitowoc Cleaner/Descaler part number 94-0546-3 and Manitowoc Sanitizer part number 94-0565-3). It is a violation of Federal law to use these solutions in a manner inconsistent with their labeling. Read and understand all labels printed on bottles before use.

REMEDIAL DESCALING/SANITIZING PROCEDURE

⚠ Caution

Do not mix Cleaner and Sanitizer solutions together. It is a violation of Federal law to use these solutions in a manner inconsistent with their labeling.

⚠ Warning

Wear rubber gloves and safety goggles (and/or face shield) when handling Ice Machine Cleaner or Sanitizer.

Ice machine descaler is used to remove lime scale and mineral deposits. Ice machine sanitizer disinfects and removes algae and slime.

Step 1 Remove front door and top cover. This will allow easiest access for adding cleaning and sanitizing solutions.

Step 2 Set the toggle switch to the OFF position after ice falls from the evaporator at the end of a Harvest cycle. Or, set the switch to the OFF position and allow the ice to melt off the evaporator.

⚠ Caution

Never use anything to force ice from the evaporator. Damage may result.

Step 3 Remove all ice from the bin/dispenser.

Step 4 Place the toggle switch in the CLEAN position. The water will flow through the water dump valve and down the drain. Wait until the water trough refills and water flows over the evaporator, then add the proper amount of ice machine cleaner.

Model	Amount of Cleaner/Descaler
S300/S320/S420	3 ounces (90 ml)
S450/S500/S600/S850/S1000/S1200	5 ounces (150 ml)
S1400/S1600/S1800	9 ounces (265 ml)
S3300/ST3000	16 ounces (475 ml)

Step 5 Wait until the clean cycle is complete (approximately *35 minutes). Then place the toggle switch in the OFF position and disconnect power to the ice machine (and dispenser when used).

NOTE: *S3300/ST3000 Only - 80 minutes.

⚠ Warning

Disconnect the electric power to the ice machine at the electric service switch box.

Step 6 Remove parts for cleaning.

Please refer to the proper parts removal for your ice machine. Continue with step 7 when the parts have been removed.

Single Evaporator Ice Machines - Page 26

Multiple Evaporator Ice Machines - Page 27

Step 7 Mix a solution of cleaner/descaler and warm water. Depending upon the amount of mineral buildup, a larger quantity of solution may be required. Use the ratio in the table below to mix enough solution to thoroughly clean all parts.

Solution Type	Water	Mixed With
Cleaner	1 gal. (4 L)	16 oz (500 ml) cleaner

Step 8 Use 1/2 of the descaler/water mixture to descale all components. The descaler solution will foam when it contacts lime scale and mineral deposits; once the foaming stops use a soft-bristle nylon brush, sponge or cloth (NOT a wire brush) to carefully clean the parts. Soak parts for 5 minutes (15 - 20 minutes for heavily scaled parts). Rinse all components with clean water.

Step 9 While components are soaking, use 1/2 of the descaler/water solution to clean all foodzone surfaces of the ice machine and bin (or dispenser). Use a nylon brush or cloth to thoroughly descale the following ice machine areas:

- Side walls
- Base (area above water trough)
- Evaporator plastic parts - including top, bottom, and sides
- Bin or dispenser

Rinse all areas thoroughly with clean water.

SANITIZING PROCEDURE

Step 10 Mix a solution of sanitizer and warm water.

Solution Type	Water	Mixed With
Sanitizer	6 gal. (23 L)	4 oz (120 ml) sanitizer

Step 11 Use 1/2 of the sanitizer/water solution to sanitize all removed components. Use a spray bottle to liberally apply the solution to all surfaces of the removed parts or soak the removed parts in the sanitizer/water solution. Do not rinse parts after sanitizing.

Step 12 Use 1/2 of the sanitizer/water solution to sanitize all foodzone surfaces of the ice machine and bin (or dispenser). Use a spray bottle to liberally apply the solution. When sanitizing, pay particular attention to the following areas:

- Side walls
- Base (area above water trough)
- Evaporator plastic parts - including top, bottom and sides
- Bin or dispenser

Do not rinse the sanitized areas.

Step 13 Replace all removed components.

Step 14 Wait 30 minutes.

Step 15 Reapply power to the ice machine and place the toggle switch in the CLEAN position.

Step 16 Wait until the water trough refills and water flows over the evaporator (approximately 3 minutes). Add the proper amount of Manitowoc Ice Machine Sanitizer to the water trough by pouring between the water curtain and evaporator.

Model	Amount of Sanitizer
S300/S320/S420	3 ounces (90 ml)
S450/S500/S600/S850/ S1000/S1200	3 ounces (90 ml)
S1400/S1600/S1800	6 ounces (180 ml)
S3300/ST3000	25 ounces (740 ml)

Step 17 Move the toggle switch to the ICE position and replace the front panel. The ice machine will automatically start ice making after the sanitize cycle is complete (approximately 35 minutes, S3300/ST3000 80 minutes).

Detailed Descaling and Sanitizing Procedure

Ice machines that are heavily scaled or have not been cleaned on a regular basis will need to run this procedure.

Clean and sanitize the ice machine every six months for efficient operation. If the ice machine requires more frequent cleaning and sanitizing, consult a qualified service company to test the water quality and recommend appropriate water treatment. The ice machine must be taken apart for cleaning and sanitizing.

⚠ Caution

Use only Manitowoc approved Ice Machine Cleaner/Descaler and Sanitizer for this application (Manitowoc Cleaner part number 94-0546-3 and Manitowoc Sanitizer part number 94-0565-3). It is a violation of Federal law to use these solutions in a manner inconsistent with their labeling. Read and understand all labels printed on bottles before use

CLEANING PROCEDURE

⚠ Caution

Do not mix Cleaner/Descaler and Sanitizer solutions together. It is a violation of Federal law to use these solutions in a manner inconsistent with their labeling.

⚠ Warning

Wear rubber gloves and safety goggles (and/or face shield) when handling Ice Machine Cleaner or Sanitizer.

Ice machine cleaner/descaler is used to remove lime scale and mineral deposits. Ice machine sanitizer disinfects and removes algae and slime.

Step 1 Set the toggle switch to the OFF position after ice falls from the evaporator at the end of a Harvest cycle. Or, set the switch to the OFF position and allow the ice to melt off the evaporator.

⚠ Caution

Never use anything to force ice from the evaporator. Damage may result.

Step 2 Remove top cover. This will allow easiest access for adding descaling and sanitizing solutions.

Step 3 Remove all ice from the bin.

Step 4 Place the toggle switch in the CLEAN position. The water will flow through the water dump valve and down the drain. Wait until the water trough refills and water flows over the evaporator, then add the proper amount of ice machine cleaner.

Model	Amount of Cleaner/Descaler
S300/S320/S420	3 ounces (90 ml)
S450/S500/S600/S850/S1000/S1200	5 ounces (150 ml)
S1400/S1600/S1800	9 ounces (265 ml)
S3300/ST3000	16 ounces (475 ml)

Step 5 Wait until the clean cycle is complete (approximately *35 minutes). Then place the toggle switch in the OFF position and disconnect power to the ice machine (and dispenser when used).

NOTE: *S3300/ST3000 Only - 80 minutes.

⚠ Warning

Disconnect the electric power to the ice machine at the electric service switch box.

Step 6 Remove parts for cleaning.

Please refer to the proper parts removal for your ice machine.

Single Evaporator Ice Machines - Page 26

Multiple Evaporator Ice Machines - Page 27

Step 7 Mix a solution of descaler and warm water. Depending upon the amount of mineral buildup, a larger quantity of solution may be required. Use the ratio in the table below to mix enough solution to thoroughly clean all parts.

Solution Type	Water	Mixed With
Descaler	1 gal. (4 L)	16 oz (500 ml) cleaner/descaler

Step 8 Use 1/2 of the descaler/water mixture to descale all components. The descaler solution will foam when it contacts lime scale and mineral deposits; once the foaming stops use a soft-bristle nylon brush, sponge or cloth (NOT a wire brush) to carefully clean the parts. Soak parts for 5 minutes (15 - 20 minutes for heavily scaled parts). Rinse all components with clean water.

Step 9 While components are soaking, use 1/2 of the descaler/water solution to descale all foodzone surfaces of the ice machine and bin (or dispenser). Use a nylon brush or cloth to thoroughly clean the following ice machine areas:

- Side walls
- Base (area above water trough)
- Evaporator plastic parts - including top, bottom, and sides
- Bin or dispenser

Rinse all areas thoroughly with clean water.

SANITIZING PROCEDURE

Step 10 Mix a solution of sanitizer and warm water.

Solution Type	Water	Mixed With
Sanitizer	6 gal. (23 L)	4 oz (120 ml) sanitizer

Step 11 Use 1/2 of the sanitizer/water solution to sanitize all removed components. Use a cloth or sponge to liberally apply the solution to all surfaces of the removed parts or soak the removed parts in the sanitizer/water solution. Do not rinse parts after sanitizing.

Step 12 Use 1/2 of the sanitizer/water solution to sanitize all foodzone surfaces of the ice machine and bin (or dispenser). Use a cloth or sponge to liberally apply the solution. When sanitizing, pay particular attention to the following areas:

- Side walls
- Base (area above water trough)
- Evaporator plastic parts - including top, bottom and sides
- Bin or dispenser

Do not rinse the sanitized areas.

Step 13 Replace all removed components.

Step 14 Reapply power to the ice machine and place the toggle switch in the CLEAN position.

Step 15 Wait about two minutes or until water starts to flow over the evaporator. Add the proper amount of Manitowoc Ice Machine Sanitizer to the water trough by pouring between the water curtain and evaporator.

Model	Amount of Sanitizer
S300/S320/S420	3 ounces (90 ml)
S450/S500/S600/S850/S1000/S1200	3 ounces (90 ml)
S1400/S1600/S1800	6 ounces (180 ml)
S3300/ST3000	25 ounces (740 ml)

Step 16 The ice machine will stop after the sanitize cycle (approximately *35 minutes). Place the toggle switch in the OFF position and disconnect power to the ice machine.

**S3300/ST3000 Only - 80 minutes.*

 Warning Disconnect the electric power to the ice machine at the electric service switch box.
--

Step 17 Refer to step 6 and disassemble components. After disassembling proceed to step 18.

Step 18 Mix a solution of sanitizer and warm water.

Solution Type	Water	Mixed With
Sanitizer	6 gal. (23 L)	4 oz (120 ml) sanitizer

Step 19 Use 1/2 of the sanitizer/water solution to sanitize all removed components. Use a cloth or sponge to liberally apply the solution to all surfaces of the removed parts or soak the removed parts in the sanitizer/water solution. Do not rinse parts after sanitizing.

Step 20 Use 1/2 of the sanitizer/water solution to sanitize all foodzone surfaces of the ice machine and bin (or dispenser). Use a cloth or sponge to liberally apply the solution. When sanitizing, pay particular attention to the following areas:

- Side walls
- Base (area above water trough)
- Evaporator plastic parts - including top, bottom and sides
- Bin or dispenser

Do not rinse the sanitized areas.

Step 21 Install the removed parts, restore power and place the toggle switch in the ICE position.

Parts Removal for Cleaning/Sanitizing

Single Evaporator Ice Machines

A. Remove the water curtain

- Gently flex the curtain in the center and remove it from the right side.
- Slide the left pin out.

B. Remove the ice thickness probe

- Compress the hinge pin on the top of the ice thickness probe.
- Pivot the ice thickness probe to disengage one pin then the other. The ice thickness probe can be cleaned at this point without complete removal. If complete removal is desired, disconnect the ice thickness control wiring from the control board.

C. Remove the evaporator tray or water diverter from the bottom of the evaporator

- Loosen thumbscrew on left side of tray.
- Allow left side of tray to drop as you pull the tray to the left side. Continue until the outlet tube disengages from the right side.

D. Remove the water trough

- Depress tabs on right and left side of the water trough.
- Allow front of water trough to drop as you pull forward to disengage the rear pins.

E. Remove the water level probe

- Pull the water level probe straight down to disengage.

- Lower the water level probe until the wiring connector is visible.
- Disconnect the wire lead from the water level probe.
- Remove the water level probe from the ice machine.

F. Remove the water pump

- Grasp pump and pull straight down on pump assembly until water pump disengages and electrical connector is visible.
- Disconnect the electrical connector.
- Remove the water pump assembly from ice machine.
- Do not soak the water pump motor in cleaner or sanitizer solution.

G. Remove the water distribution tube

NOTE: Distribution tube thumbscrews are retained to prevent loss. Loosen thumbscrews but do not pull thumbscrews out of distribution tube.

- Loosen the two outer screws (do not remove screws completely they are retained to prevent loss) and pull forward on the distribution tube to release from slip joint.
- Disassemble distribution tube by loosening the two (2) middle thumbscrews and dividing the distribution tube into two pieces.

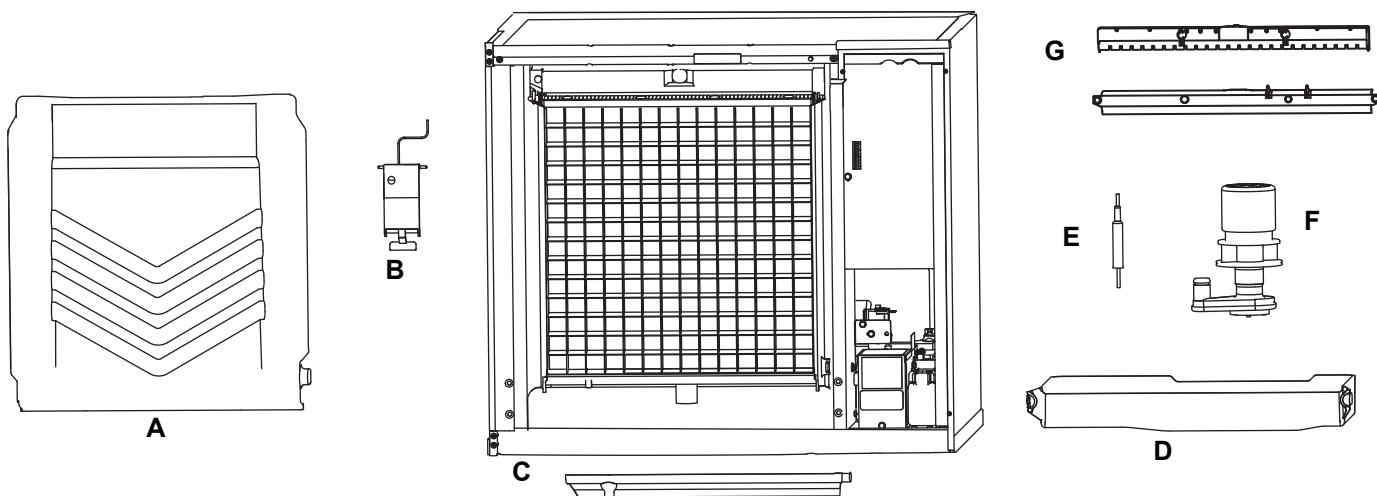

Multiple Evaporator Ice Machines

A. Remove front evaporator shield

- Remove four quarter turn connectors.
- Remove splash shield.

B. Remove left and right evaporator top covers

- Remove two thumbscrews from the front of each evaporator top cover.
- Lift front of cover, pull forward to remove.

C. Remove splash shields

NOTE: Each evaporator has a splash shield that must be removed - total of four splash shields.

- Grasp the top center of splash shields.
- Lift up and then out.

D. Remove ice thickness probe

- Compress the hinge pin on the top of the ice thickness probe.
- Pivot the ice thickness probe to disengage one pin then the other. The ice thickness probe can be cleaned at this point without complete removal. If complete removal is desired, disconnect the ice thickness control wiring from the control board.

E. Remove the water pump assembly

- Disconnect the vinyl distribution tube from both water pumps.
- Disconnect the water pump and water level probe electrical connections.
- After the wires are disconnected remove the two thumbscrews and lift the water pump assembly out of the ice machine.

- Remove the thumbscrews securing the water pumps (2 each pump) and remove water pumps. Do not immerse the water pump motor in cleaner or sanitizer solutions.
- Remove the water level probe from the assembly housing.

F. Remove the water trough

- Pull forward on the water trough to remove.

G. Remove distribution tubes

NOTE: Each evaporator has a distribution that must be removed - total of four distribution tubes.

- Distribution tube thumbscrews are retained to prevent loss. Loosen thumbscrews but do not pull thumbscrews out of distribution tube.
- Loosen the two outer screws and pull forward on the distribution tube to release from slip joint.
- Disassemble distribution tube by loosening the two (2) middle thumbscrews and dividing the distribution tube into two pieces.

H. Remove ice dampers

NOTE: Each evaporator has an ice damper that must be removed - total of four ice dampers.

- Grasp ice damper and apply pressure toward the back mounting bracket.
- Apply pressure to the front mounting bracket with thumb.
- Pull ice damper downward when the front ice damper pin disengages.

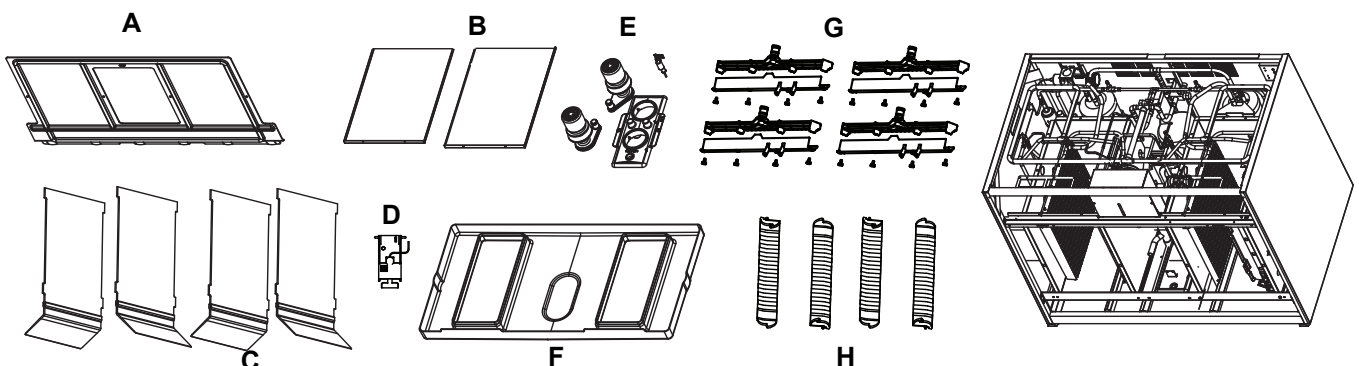

Exterior Cleaning

Clean the area around the ice machine as often as necessary to maintain cleanliness and efficient operation. Use cleaners designed for use with stainless steel products.

Sponge any dust and dirt off the outside of the ice machine with mild soap and water. Wipe dry with a clean, soft cloth.

Heavy stains should be removed with stainless steel wool. Never use plain steel wool or abrasive pads. They will scratch the panels.

Door Removal

1. Use a phillips screwdriver to loosen the two screws securing the left and right doors. Do not remove they are secured to prevent loss.
2. 30 Inch and 48 Inch Models: To remove right front door lift up and remove (22 inch ice machines have a single door, lift to remove entire door).

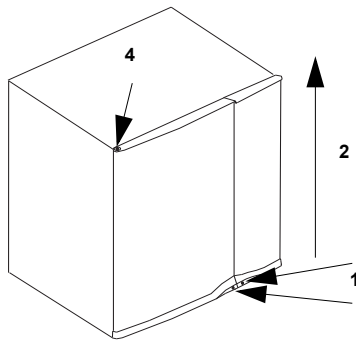

Door Removal

3. Open left front door to 45 degrees.
4. Support with right hand, depress top pin, tilt top of door forward and lift out of bottom pin to remove.

Cleaning the Condenser

GENERAL

Warning

Disconnect electric power to the ice machine head section and the remote condensing unit at the electric service switches before cleaning the condenser.

A dirty condenser restricts airflow, resulting in excessively high operating temperatures. This reduces ice production and shortens component life.

- Clean the condenser at least every six months.

Warning

The condenser fins are sharp. Use care when cleaning them.

- Shine a flashlight through the condenser to check for dirt between the fins.
- Blow compressed air or rinse with water from the inside out (opposite direction of airflow).
- If dirt still remains call a service agent to clean the condenser.

Removal from Service/Winterization

1. Clean and sanitize the ice machine.
2. Move the ICE/OFF/CLEAN switch to OFF.
3. Turn off the water supply, disconnect and drain the incoming ice-making water line at the rear of the ice machine and drain the water trough.
4. Energize the ice machine, wait one minute for the water inlet valve to open and blow compressed air in both the incoming water and the drain openings in the rear of the ice machine to remove all water.
5. Move ICE/OFF/CLEAN switch to OFF and disconnect the electric power at the circuit breaker or the electric service switch.
6. Fill spray bottle with sanitizer and spray all interior food zone surfaces. Do not rinse and allow to air dry.
7. Replace all panels.

Section 5

Customer Support

Checklist

If a problem arises during operation of your ice machine, follow the checklist below before calling service. Routine adjustments and maintenance procedures are not covered by the warranty.

Problem	Possible Cause	To Correct
Ice machine does not operate.	No electrical power to the ice machine and/or condensing unit.	Replace the fuse/reset the breaker/turn on the main switch.
	High pressure cutout tripping.	Clean condenser coil. (See Section 4)
	ICE/OFF/CLEAN toggle switch set improperly.	Move the toggle switch to the ICE position.
	Water curtain stuck open.	Water curtain must be installed and swinging freely. (See Section 4)
	Remote receiver service valve and/or Liquid/suction line shut off valves are closed.	Open the valve(s). (See Section 2)
Ice machine stops, and can be restarted by moving the toggle switch to OFF and back to ICE.	Safety limit feature stopping the ice machine.	Refer to "Safety Limit Feature" on the next page.
Ice machine does not release ice or is slow to harvest.	Ice machine is dirty.	Clean and sanitize the ice machine. (See Section 4)
	Ice machine is not level.	Level the ice machine. (See Section 2)
	Low air temperature around ice machine head section.	Air temperature must be at least 35°F (1.6°C).
	Fan cycling control does not de-energize condenser fan motor.	Verify pressure is below cut-out setpoint, replace fan cycling control.
Ice machine does not cycle into harvest mode.	The six-minute freeze time lock-in has not expired yet.	Wait for the freeze lock-in to expire.
	Ice thickness probe is dirty.	Clean and sanitize the ice machine. (See Section 4)
	Ice thickness probe is disconnected.	Connect the wire.
	Ice thickness probe is out of adjustment.	Adjust the ice thickness probe. (See Section 3)
	Uneven ice fill (thin at the top of evaporator).	Verify sufficient water level in sump trough. Contact a qualified service company to check refrigeration system.
Ice quality is poor (soft or not clear).	Poor incoming water quality.	Contact a qualified service company to test the quality of the incoming water and make appropriate filter recommendations.
	Water filtration is poor.	Replace the filter.
	Ice machine is dirty.	Clean and sanitize the ice machine. (See Section 4)
	Water dump valve is not working.	Disassemble and clean the water dump valve. (See Section 4)
	Water softener is working improperly (if applicable).	Repair the water softener.

Problem	Possible Cause	To Correct
Ice machine produces shallow or incomplete cubes, or the ice fill pattern on the evaporator is incomplete.	Ice thickness probe is out of adjustment.	Adjust the ice thickness probe. (See Section 4)
	Water trough level is too low.	Check the water level probe for damage. (See Section 3)
	Water inlet valve filter screen is dirty.	Remove the water inlet valve and clean the filter screen. (See Section 4)
	Water filtration is poor.	Replace the filter.
	Hot incoming water.	Connect the ice machine to a cold water supply. (See Section 2)
	Water inlet valve is not working.	Replace the water inlet valve.
	Incorrect incoming water pressure.	Water pressure must be 20-80 psi (1.4 bar - 5.5 bar).
	Ice machine is not level.	Level the ice machine. (See Section 2)
Low ice capacity.	Water inlet valve filter screen is dirty.	Remove the water inlet valve and clean the filter screen. (See Section 4)
	Incoming water supply is shut off.	Open the water service valve.
	Water inlet valve stuck open or leaking.	Place toggle switch in OFF position, if water continues to enter water trough replace the water inlet valve.
	The condenser is dirty.	Clean the condenser. (See Section 4)
	High air temperature entering condenser.	Air temperature must not exceed 120°F (39°C).
	The harvest assist air compressor is not functioning.	Call for service.

Safety Limit Feature

In addition to the standard safety controls, such as the high pressure cutout, your Manitowoc ice machine features built-in safety limits which will stop the ice machine if conditions arise which could cause a major component failure.

Before calling for service, re-start the ice machine using the following procedure:

1. Move the ICE/OFF/CLEAN switch to OFF and then back to ICE.
 - A. If the safety limit feature has stopped the ice machine, it will restart after a short delay. Proceed to step 2.
 - B. If the ice machine does not restart, see "Ice machine does not operate" on the previous page.
2. Allow the ice machine to run to determine if the condition is recurring.
 - A. If the ice machine stops again, the condition has recurred. Call for service.
 - B. If the ice machine continues to run, the condition has corrected itself. Allow the ice machine to continue running.

Commercial Ice Machine Warranty

Manitowoc Ice, Inc. (hereinafter referred to as the "COMPANY") warrants for a period of thirty-six months from the installation date (except as limited below) that new ice machines manufactured by the COMPANY shall be free of defects in material or workmanship under normal and proper use and maintenance as specified by the COMPANY and upon proper installation and start-up in accordance with the instruction manual supplied with the ice machine. The COMPANY's warranty hereunder with respect to the compressor shall apply for an additional twenty-four months, excluding all labor charges, and with respect to the evaporator for an additional twenty-four months, including labor charges.

The obligation of the COMPANY under this warranty is limited to the repair or replacement of parts, components, or assemblies that in the opinion of the COMPANY are defective. This warranty is further limited to the cost of parts, components or assemblies and standard straight time labor charges at the servicing location.

Time and hourly rate schedules, as published from time to time by the COMPANY, apply to all service procedures. Additional expenses including without limitation, travel time, overtime premium, material cost, accessing or removal of the ice machine, or shipping are the responsibility of the owner, along with all maintenance, adjustments, cleaning, and ice purchases. Labor covered under this warranty must be performed by a COMPANY Contracted Service Representative or a refrigeration service agency as qualified and authorized by the COMPANY's local Distributor. The COMPANY's liability under this warranty shall in no event be greater than the actual purchase price paid by customer for the ice machine.

The foregoing warranty shall not apply to (1) any part or assembly that has been altered, modified, or changed; (2) any part or assembly that has been subjected to misuse, abuse, neglect, or accidents; (3) any ice machine that has been installed and/or maintained inconsistent with the technical instructions provided by the COMPANY; or (4) any ice machine initially installed more than five years from the serial number production date. This warranty shall not apply if the Ice Machine's refrigeration system is modified with a condenser, heat reclaim device, or parts and assemblies other than those manufactured by the COMPANY, unless the COMPANY approves these modifications for specific locations in writing.

THIS WARRANTY IS IN LIEU OF ALL OTHER WARRANTIES OR GUARANTEES OF ANY KIND, EXPRESSED OR IMPLIED, INCLUDING ANY IMPLIED WARRANTY OF MERCHANTABILITY OR FITNESS FOR A PARTICULAR PURPOSE. In no event shall the COMPANY be liable for any special, indirect, incidental or consequential damages. Upon the expiration of the warranty period, the COMPANY's liability under this warranty shall terminate. The foregoing warranty shall constitute the sole liability of the COMPANY and the exclusive remedy of the customer or user.

To secure prompt and continuing warranty service, the warranty registration card must be completed and sent to the COMPANY within five (5) days from the installation date.

Complete the following and retain for your record:

Distributor/Dealer _____
Model Number _____ Serial Number _____
Installation Date _____

MANITOWOC ICE, INC.
2110 So. 26th St., P.O. Box 1720, Manitowoc, WI 54221-1720
Telephone: 920-682-0161 • Fax: 920-683-7585
Web Site - www.manitowocice.com
Form 80-0375-3 Rev. 01-02

Residential Ice Machine Limited Warranty

WHAT DOES THIS LIMITED WARRANTY COVER?

Subject to the exclusions and limitations below, Manitowoc Foodservice ("Manitowoc") warrants to the original consumer that any new ice machine manufactured by Manitowoc (the "Product") shall be free of defects in material or workmanship for the warranty period outlined below under normal use and maintenance, and upon proper installation and start-up in accordance with the instruction manual supplied with the Product.

HOW LONG DOES THIS LIMITED WARRANTY LAST?

<u>Product Covered</u>	<u>Warranty Period</u>
Ice Machine	Twelve (12) months from the sale date

WHO IS COVERED BY THIS LIMITED WARRANTY?

This limited warranty only applies to the original consumer of the Product and is not transferable.

WHAT ARE MANITOWOC ICE'S OBLIGATIONS UNDER THIS LIMITED WARRANTY?

If a defect arises and Manitowoc receives a valid warranty claim prior to the expiration of the warranty period, Manitowoc shall, at its option: (1) repair the Product at Manitowoc's cost, including standard straight time labor charges, (2) replace the Product with one that is new or at least as functionally equivalent as the original, or (3) refund the purchase price for the Product. Replacement parts are warranted for 90 days or the balance of the original warranty period, whichever is longer. The foregoing constitutes Manitowoc's sole obligation and the consumer's exclusive remedy for any breach of this limited warranty. Manitowoc's liability under this limited warranty is limited to the purchase price of Product. Additional expenses including, without limitation, service travel time, overtime or premium labor charges, accessing or removing the Product, or shipping are the responsibility of the consumer.

HOW TO OBTAIN WARRANTY SERVICE

To obtain warranty service or information regarding your Product, please contact us at:

MANITOWOC FOODSERVICE

2110 So. 26th St.

P.O. Box 1720,

Manitowoc, WI 54221-1720

Telephone: 920-682-0161 Fax: 920-683-7585

www.manitowocice.com

WHAT IS NOT COVERED?

This limited warranty does not cover, and you are solely responsible for the costs of: (1) periodic or routine maintenance, (2) repair or replacement of the Product or parts due to normal wear and tear, (3) defects or damage to the Product or parts resulting from misuse, abuse, neglect, or accidents, (4) defects or damage to the Product or parts resulting from improper or unauthorized alterations, modifications, or changes; and (5) defects or damage to any Product that has not been installed and/or maintained in accordance with the instruction manual or technical instructions provided by Manitowoc. To the extent that warranty exclusions are not permitted under some state laws, these exclusions may not apply to you.

EXCEPT AS STATED IN THE FOLLOWING SENTENCE, THIS LIMITED WARRANTY IS THE SOLE AND EXCLUSIVE WARRANTY OF MANITOWOC WITH REGARD TO THE PRODUCT. ALL IMPLIED WARRANTIES ARE STRICTLY LIMITED TO THE DURATION OF THE LIMITED WARRANTY APPLICABLE TO THE PRODUCTS AS STATED ABOVE, INCLUDING BUT NOT LIMITED TO, ANY WARRANTY OF MERCHANTABILITY OR OF FITNESS FOR A PARTICULAR PURPOSE.

Some states do not allow limitations on how long an implied warranty lasts, so the above limitation may not apply to you.

IN NO EVENT SHALL MANITOWOC OR ANY OF ITS AFFILIATES BE LIABLE TO THE CONSUMER OR ANY OTHER PERSON FOR ANY INCIDENTAL, CONSEQUENTIAL OR SPECIAL DAMAGES OF ANY KIND (INCLUDING, WITHOUT LIMITATION, LOSS PROFITS, REVENUE OR BUSINESS) ARISING FROM OR IN ANY MANNER CONNECTED WITH THE PRODUCT, ANY BREACH OF THIS LIMITED WARRANTY, OR ANY OTHER CAUSE WHATSOEVER, WHETHER BASED ON CONTRACT, TORT OR ANY OTHER THEORY OF LIABILITY.

Some states do not allow the exclusion or limitation of incidental or consequential damages, so the above limitation or exclusion may not apply to you.

HOW STATE LAW APPLIES

This limited warranty gives you specific legal rights, and you may also have rights that vary from state to state or from one jurisdiction to another.

REGISTRATION CARD

To secure prompt and continuing warranty service, this warranty registration card must be completed and sent to Manitowoc within thirty (30) days from the sale date. Complete the following registration card and send it to Manitowoc.



Manitowoc Ice
2110 South 26th Street Manitowoc, WI
54220

800-545-5720

www.manitowocice.com



Welbilt offers fully-integrated kitchen systems and our products are backed by KitchenCare® aftermarket parts and service. Welbilt's portfolio of award-winning brands includes **Cleveland™**, **Convotherm®**, **Crem®**, **Delfield®**, **fitkitchen®**, **Frymaster®**, **Garland®**, **Kolpak®**, **Lincoln®**, **Manitowoc®**, **Merco®**, **Merrychef®** and **Multiplex®**.

Bringing innovation to the table • welbilt.com